

HAMPTON CAST STONE LIMITED

Unit 7, Merretts Mill

Woodchester, Stroud, Glos, GL5 5EU

Tel: 01453-836677 Fax: 01453-835005

email:sales@hamptoncaststone.co.uk

INDEX OF PAGES

Hampton Stone Profile and Contact Details

Quoins

Copings and Pier Caps

Cill's

Lintels

Chimney Capping

Corbels

Air Bricks and Gable Vents

Name stone & Date stone

Window Surrounds – Traditional

Window Surrounds – Circular and Oval

Window Surrounds – Bulls eye

Door Surrounds

Ball Finials

Balustrading

Columns

Fireplace – Classic

Conditions of Sales

Additional Standard Precast Units

PROFILE

Hampton Cast Stone Limited have craftsmen who have between them over 50 years of experience, manufacturing cast stone products, including Architectural Feature Stone, Traditional Cotswold Castings, together with such varied items as Fireplaces, Garden Furniture and other bespoke 'one-off' items. In August 2008 the company was taken over by new Directors.

The company's activities are largely concerned with individual contracts in cast stone, but it still supplies standard items such as copings and lintels. All products are backed by proven longevity, consistency of finish and regular testing in accordance with British Standard specifications.

The company employs a Technical Consultant who is involved in the research and development of new products and finishes. Moulds are prepared by the in-house carpentry shop and casting is produced using aggregates from all over the country to reproduce the shading of natural stone, with other colours available to order.

PRODUCT CATALOGUE

Our product catalogue contains details of most of our standard products but, since new designs are constantly being added, others may be available which are not listed. Please ring for current prices and availability.

Should you require any item not included within these pages, you are most welcome to contact us with detailed drawings for a special quotation to be prepared. Our Estimator can be contacted as follows:-

Telephone on 01453-836677
Fax on 01453-835005
Email on sales@hamptoncaststone.co.uk

Or at Hampton Cast Stone Limited, Unit 7, Merretts Mill, Woodchester, Stroud, Glos, GL5 5EU.

STANDARD QUOINS.

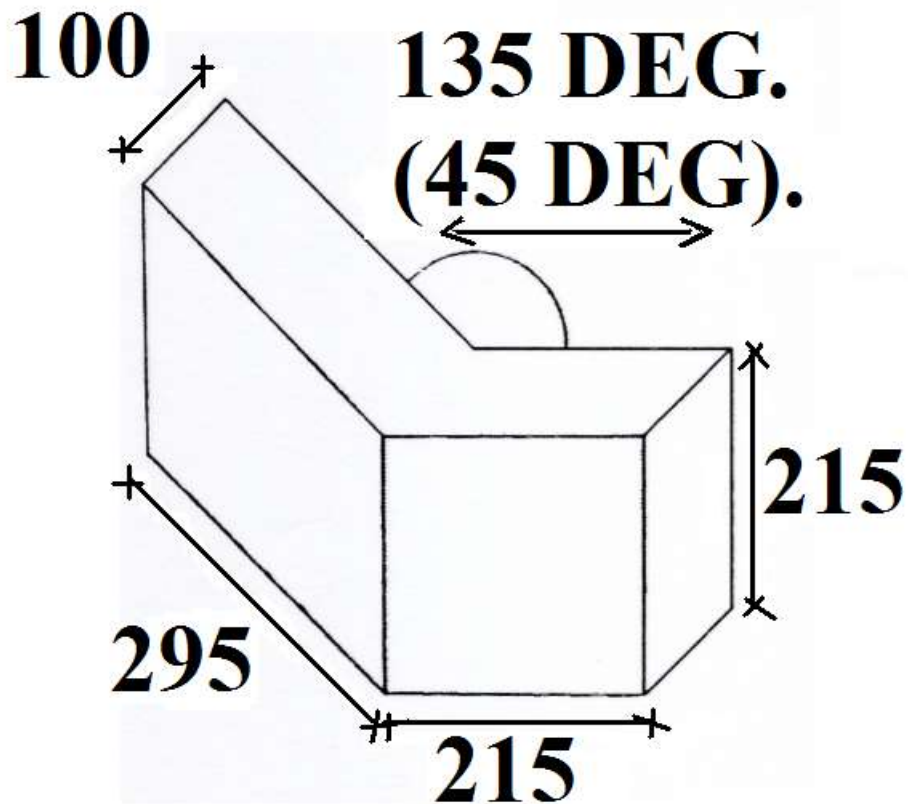

135 DEGREE RETURN QUOINS.

FACED ON TWO SIDE

EITHER EXTERNALLY OR INTERNALLY.

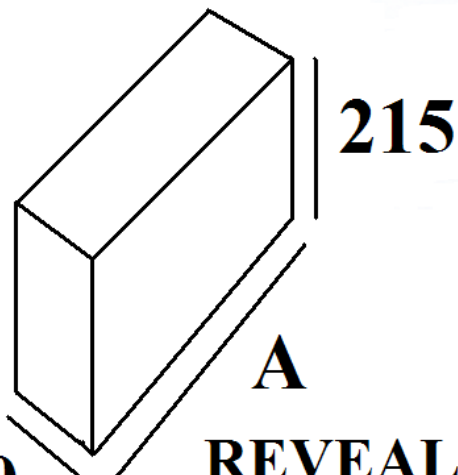

- 140 X 100 X 215 MM HIGH
- 215 X 100 X 215 MM HIGH
- 295 X 100 X 215 MM HIGH
- 327 X 100 X 215 MM HIGH
- 440 X 100 X 215 MM HIGH

100

REVEAL QUOINS.

faced front & one end.

STANDARD QUOINS.

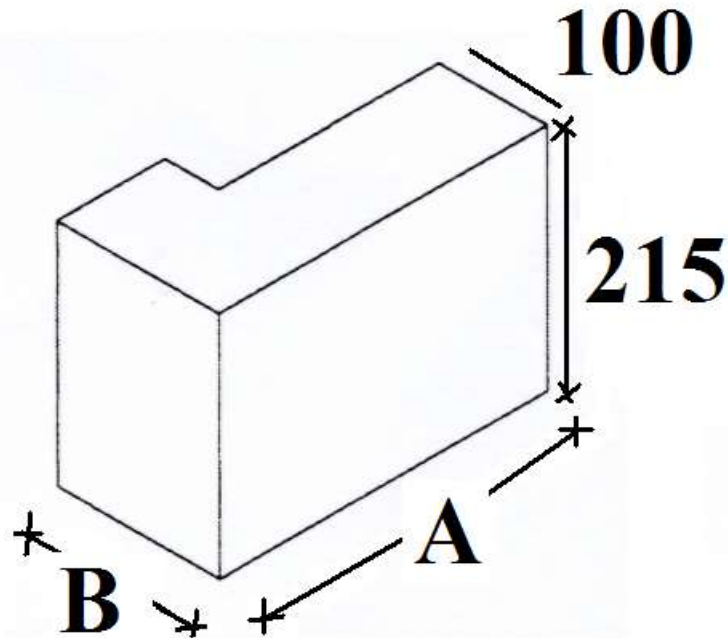

90 DEGREE RETURN QUOIN.

FACED ON TWO SIDE

EITHER EXTERNALLY OR INTERNALLY.

A B

295 X 140 X 100 X 140 MM HIGH

215 X 215 X 100 X 215 MM HIGH

295 X 140 X 100 X 215 MM HIGH

295 X 215 X 100 X 215 MM HIGH

327 X 215 X 100 X 215 MM HIGH

440 X 215 X 100 X 215 MM HIGH

OTHER SIZES CAN BE MADE TO ORDER.

PRICES AVAILABLE ON REQUEST.

COPING.

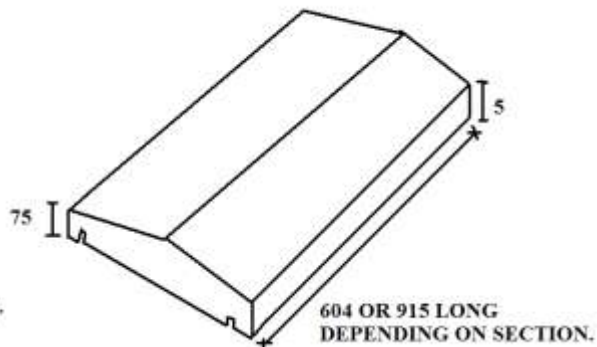
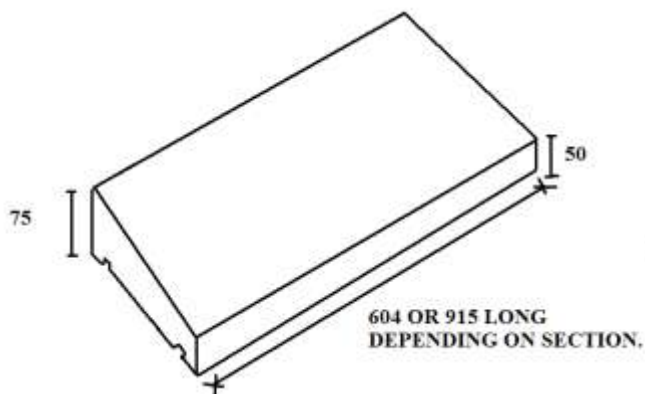

ONCE WEATHERED COPING (O/W)

TWICE-WEATHERED COPING (T/W)

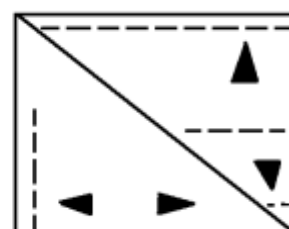
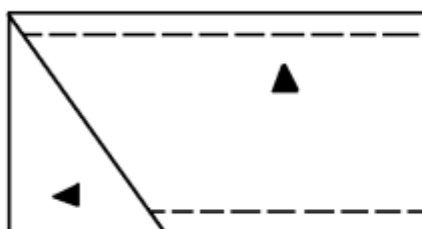
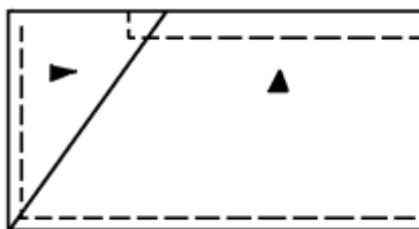

**L/H EXTERNAL
RETURN, O/W coping**

**L/H INTERNAL
RETURN.O/W**

**RIGHT ANGEL
RETURN T/W**

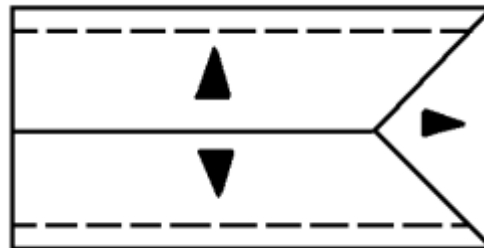

**R/H FACED T/W coping.
(STOPPED END)**

**RETURN (STOPPED END)
T/W COPING.**

**OTHER STANDARD SIZES AVAILABLE; 457MM. 533MM &
610MM WIDE.**

SWEPT PIER CAPS

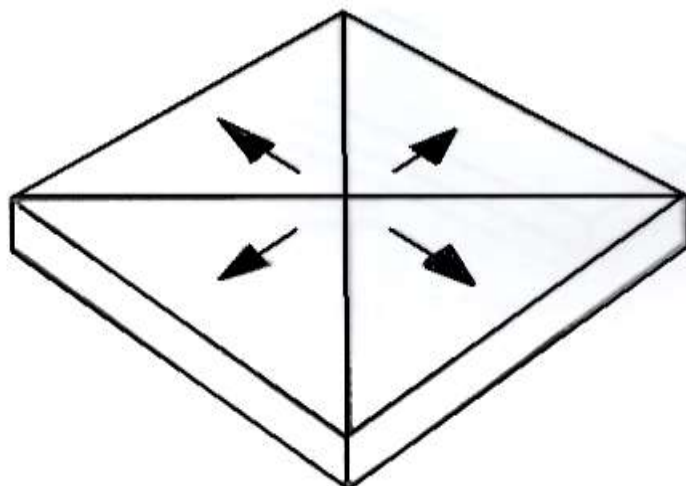

Standard Pier Caps – four times weathered

FPC12/B	305 x 305 x 75-50mm high
FPC16.5/B	420 x 420 x 75-50mm high
FPC21/B	534 x 534 x 75-50mm high
FPC27/B	685 x 685 x 75-50mm high
FPC760	760 x 760 x 115-50mm high
FPC420	420 x 420 x 115-50mm high
FPC534	534 x 534 x 115-50mm high
FPC685	685 x 685 x 115-50mm high
FPC635	635 x 635 x 115-50mm high

Moulded Pier Cap

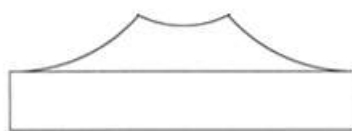

760 x 760mm

CILLS

A  **B**
C

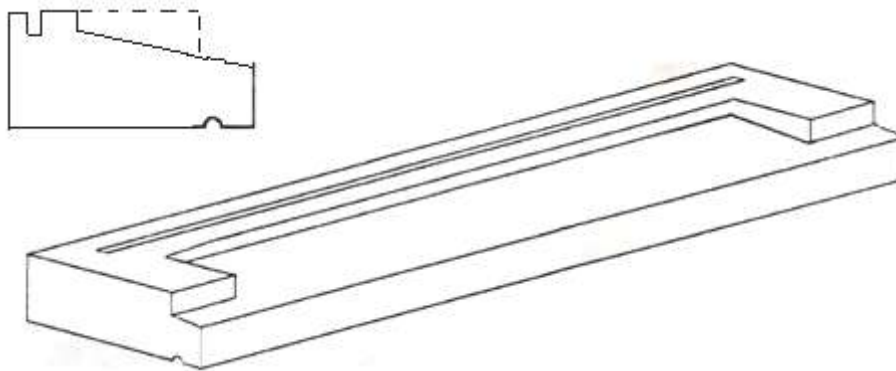
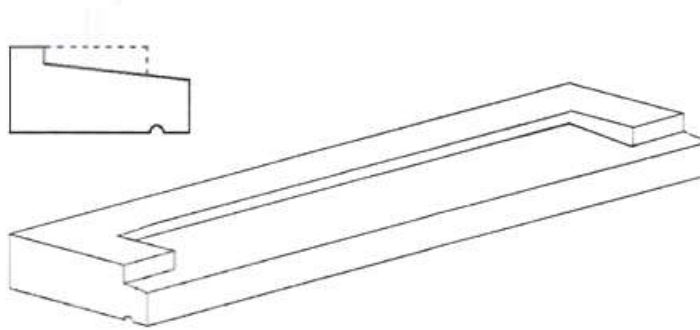
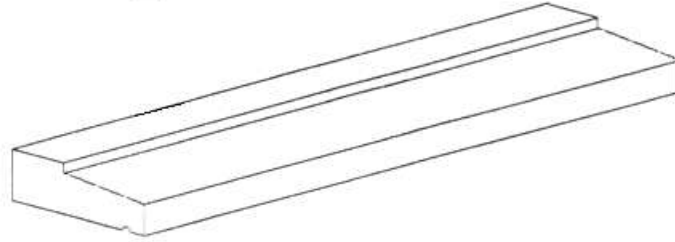

STANDARD CILL SECTIONS

All sizes are available with or without stooling's / groove for water-bar

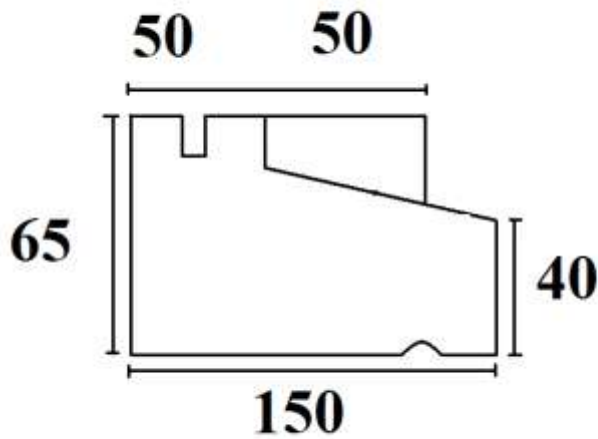

150 X 65 MM HIGH

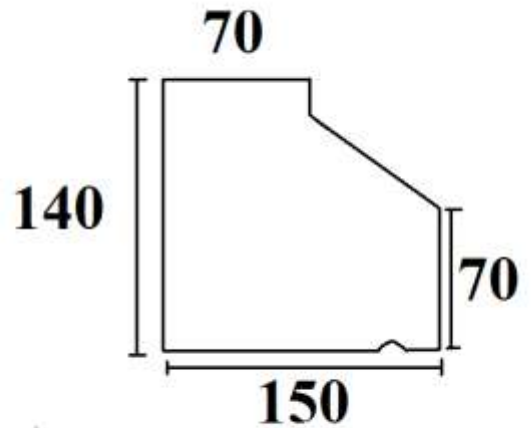

150 X 140 MM HIGH

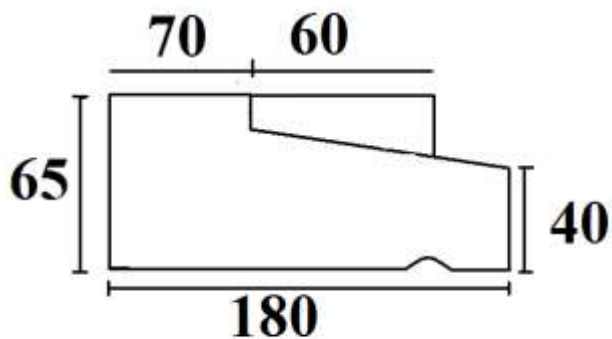

180 X 65 MM HIGH.

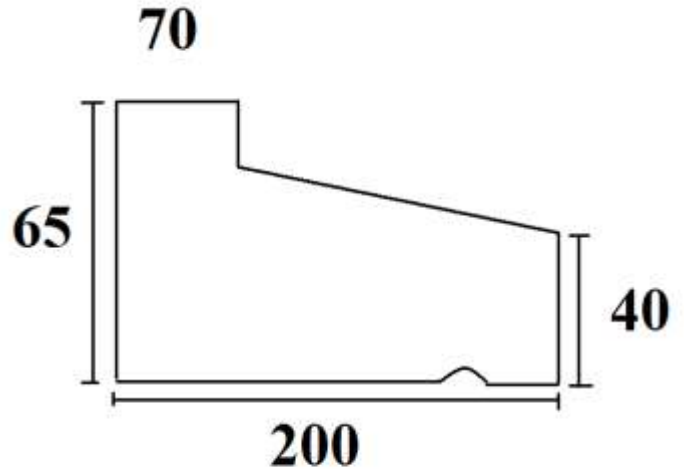

200 X 65 MM HIGH.

STANDARD CILL SECTIONS

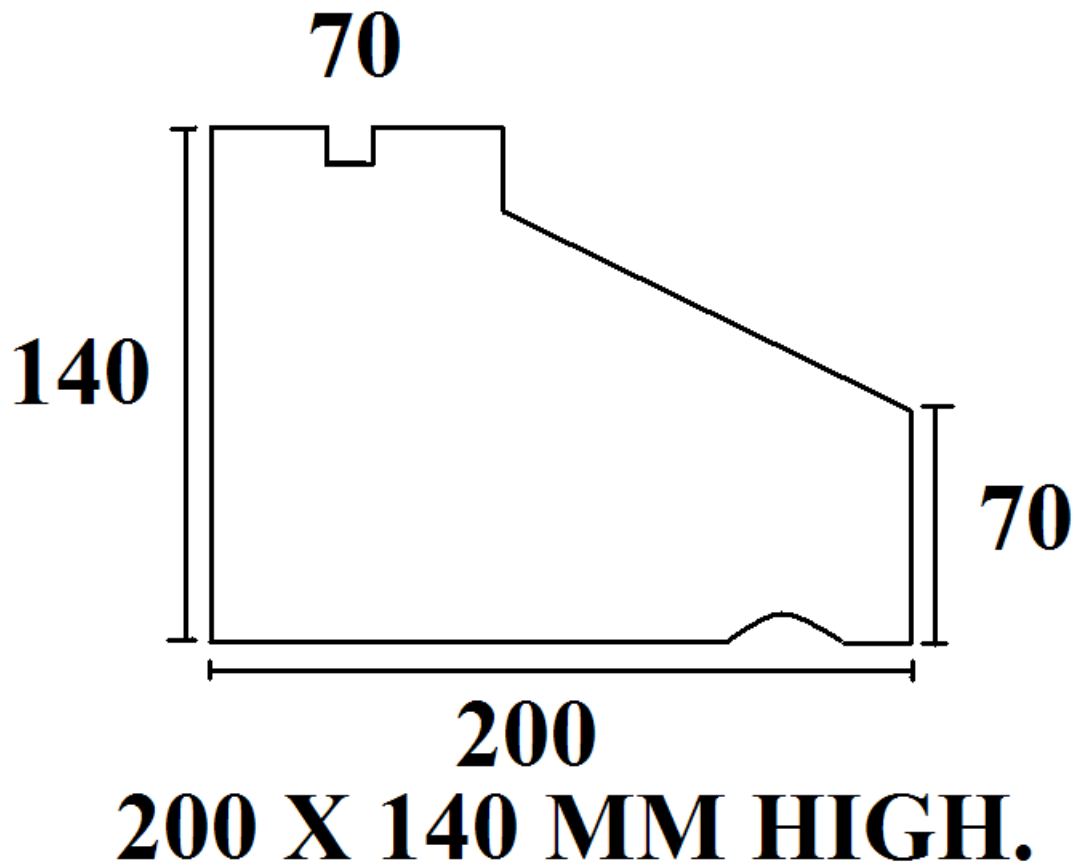
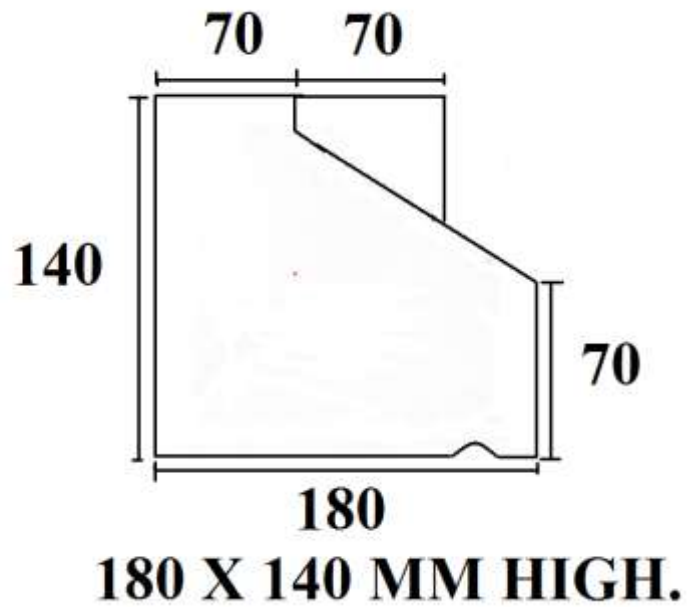
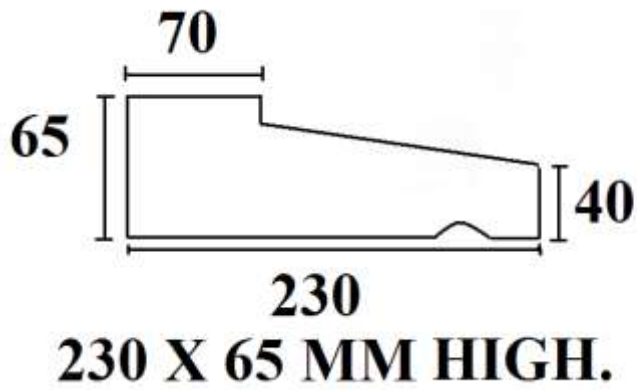

CILL'S ALSO AVAILABLE.

230 x 140mm high 165 x 65mm high-

305 x 100mm high 140 x 215mm high

275 x 140mm high 355 x 140mm high

416 x 140mm high

Maximum length in one piece is 1500mm –

Cill's exceeding this will be made in two pieces or more, depending on overall length.

CAST STONE LINTOLS

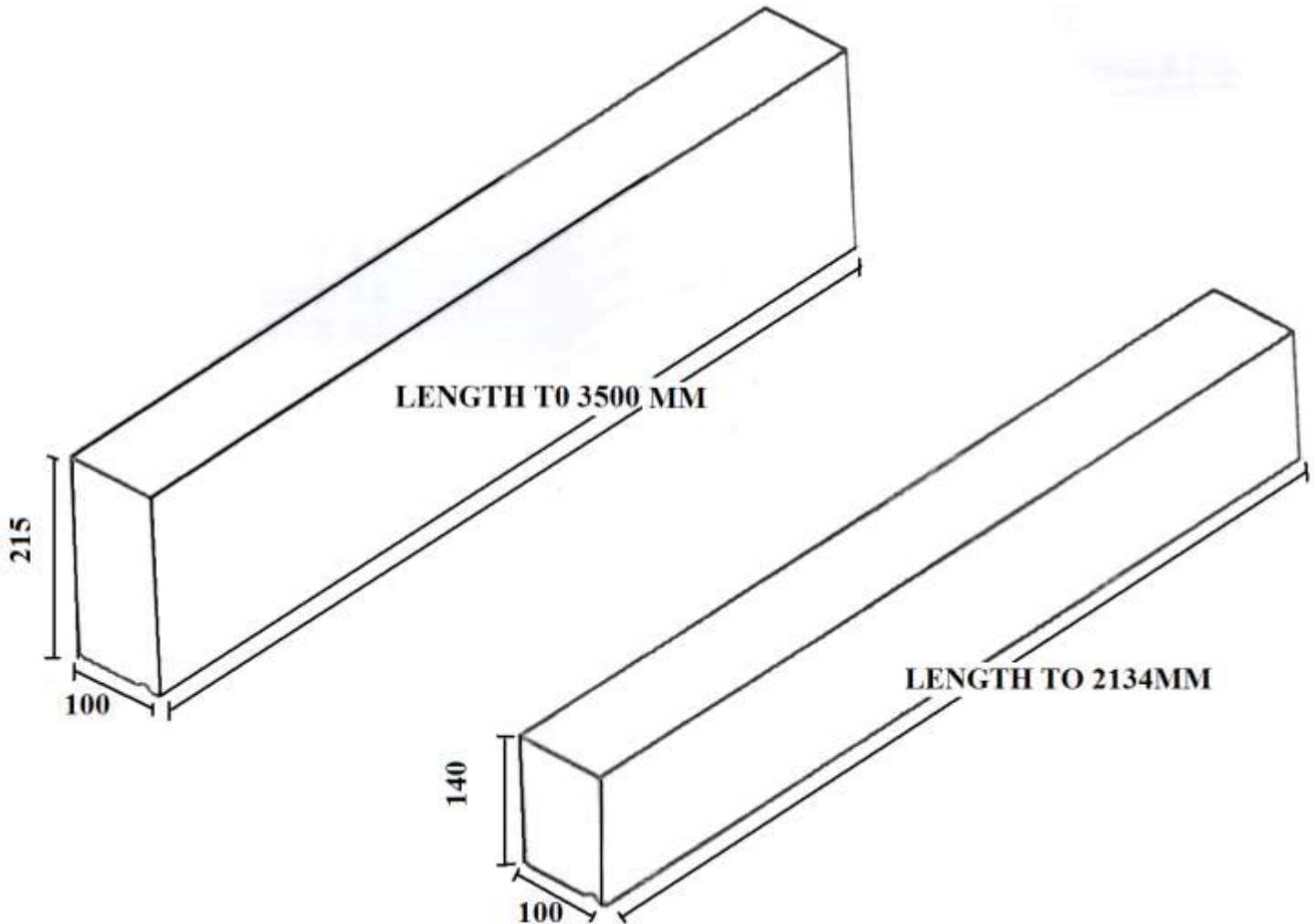

All Hampton Cast Stone lintels are reinforced for self – weight and handling purposes and for structural (load bearing) use – see over for details.

They would satisfactorily support uniformly distributed loadings of 3KN / meter run.

Available in Faced or Rough Cast finish

REINFORCING TO STD LINTOLS.

	Length	Bottom Reinforcement	Top Reinforcement
<u>100 x 140mm high section (4" x 6")</u>			
915mm	(3'0")	1 x 10mm	1 x 6mm
1067mm	(3'6")	1 x 10mm	1 x 6mm
1216mm	(4'0")	1 x 10mm	1 x 8mm
1372mm	(4'6")	2 x 8mm	1 x 8mm
1524mm	(5'0")	2 x 8mm	1 x 8mm
1677mm	(5'6")	2 x 10mm	1 x 8mm
1829mm	(6'0")	2 x 12mm	2 x 8mm
1981mm	(6'6")	2 x 16mm	2 x 8mm
2134mm	(7'0")	2 x 16mm	2 x 8mm

100 x 220mm high section (4' x 9")

915mm	(3'0")	1 x 6mm	
1067mm	(3'6")	1 x 10mm	
1216mm	(4'0")	1 x 12mm	1 x 6mm
1372mm	(4'6")	1 x 12mm	1 x 8mm

REINFORCING TO STD LINTOLS.

1524mm	(5'0")	1 x 12mm	1 x 6mm
1677mm	(5'6")	2 x 10mm	1 x 8mm
1829mm	(6'0")	2 x 12mm	1 x 8mm
1981mm	(6'6")	2 x 12mm	1 x 8mm
2134mm	(7'0")	2 x 12mm	1 x 8mm
2286mm	(7'6")	2 x 12mm	1 x 8mm
2439mm	(8'0")	2 x 16mm	1 x 12mm
2581mm	(8'6")	2 x 16mm	1 x 12mm
2744mm	(9'0")	2 x 16mm	1 x 12mm
2896mm	(9'6")	2 x 16mm	1 x 12mm
3050mm	(10'0")	2 x 20mm	1 x 12mm
3200mm	(10'6")	2 x 20mm	1 x 12mm
3506mm	(11'6")	2 x 20mm	1 x 12mm

High-tensile reinforcement is used as standard, but can be replaced with stainless steel, if required, at additional cost.

Please contact us for information on lintels in excess of 3.5 meters in length.

CHIMNEY CAPPING

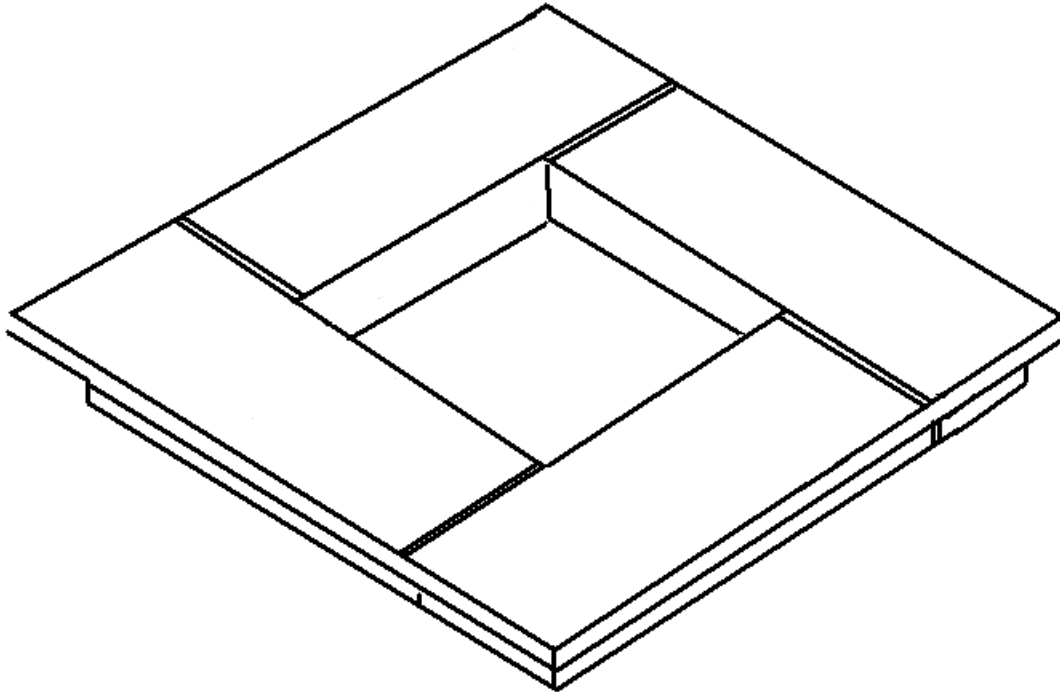

OG MOULDED

200

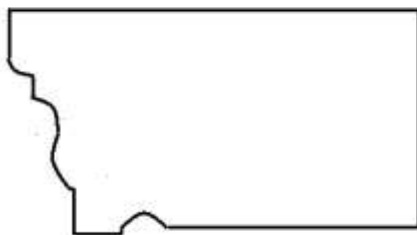

84

165

X 935MM LENGTHS

ANGLED

215

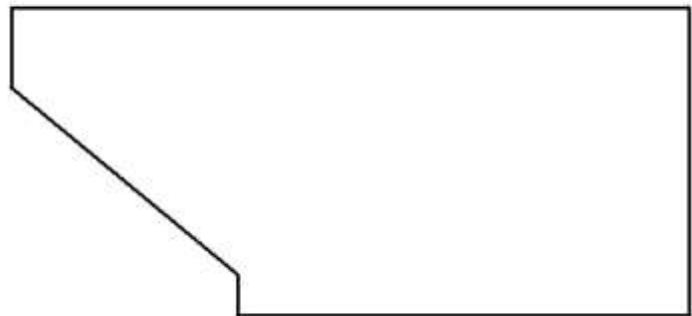

75

165

X 745MM LENGTHS



CHIMNEY COPING

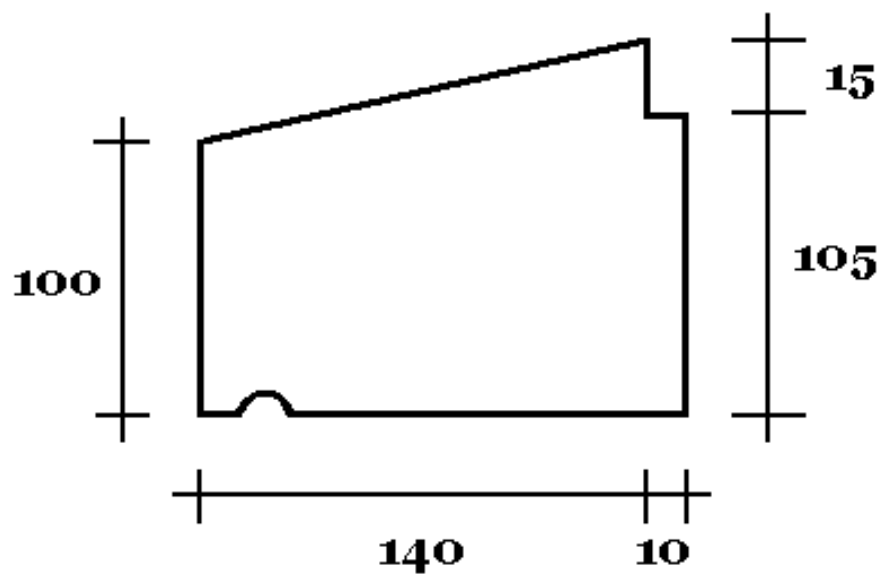
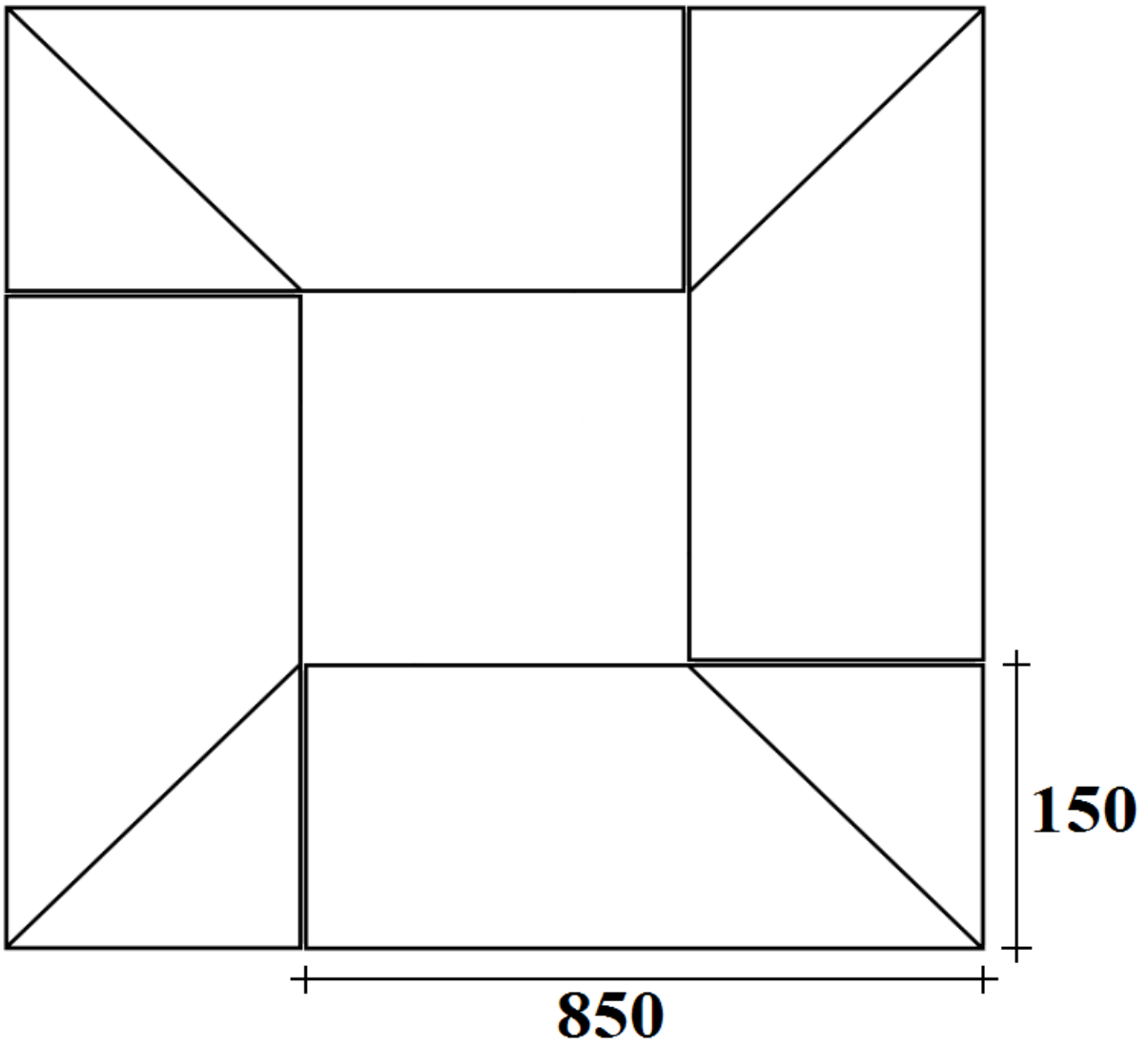

CORBELS

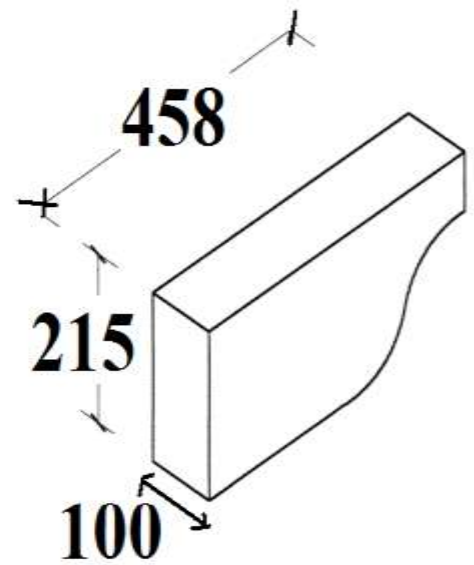
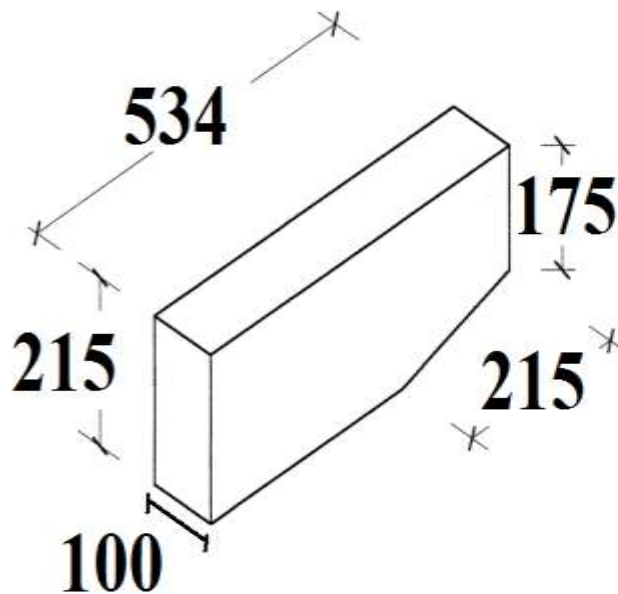

ANGLED FACE

OG FACE

Both corbels are available in all the following sizes:

458 x 100 x 140mm high

458 x 100 x 215mm high

534 x 100 x 140mm high

534 x 100 x 215mm high

AIR BRICKS.

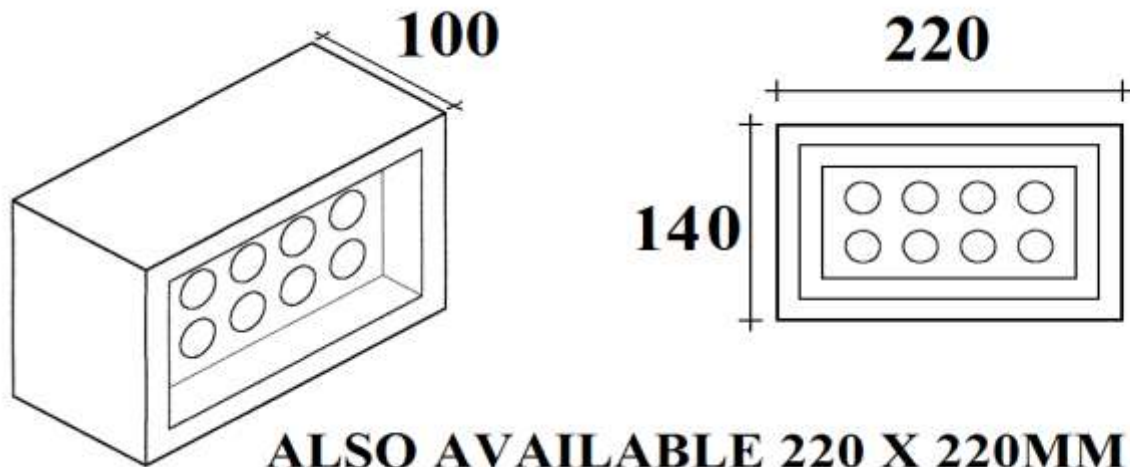

ALSO AVAILABLE 220 X 220MM SQUARE.

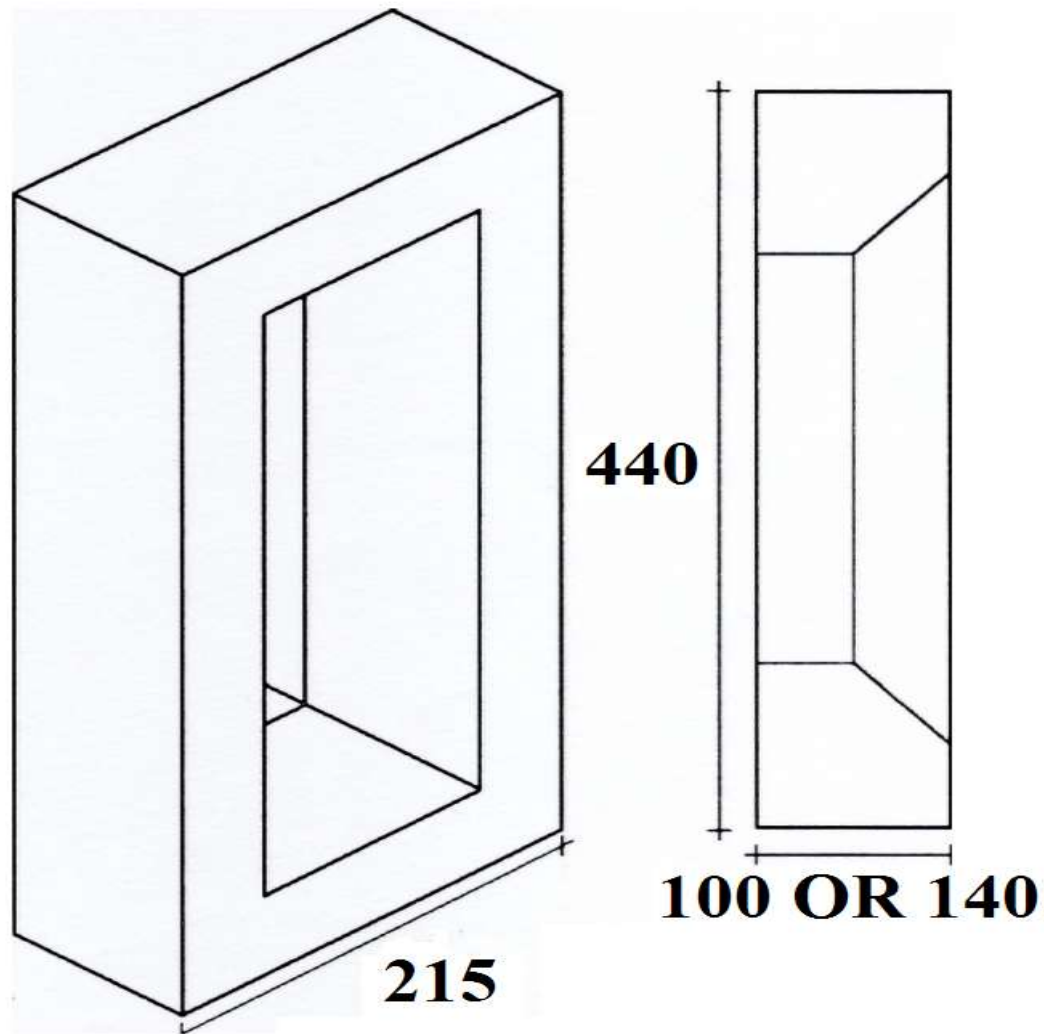

ALSO AVAILABLE : 665 X 100 X 327 MM
GABLE VENT

NAMESTONE & DATESTONES

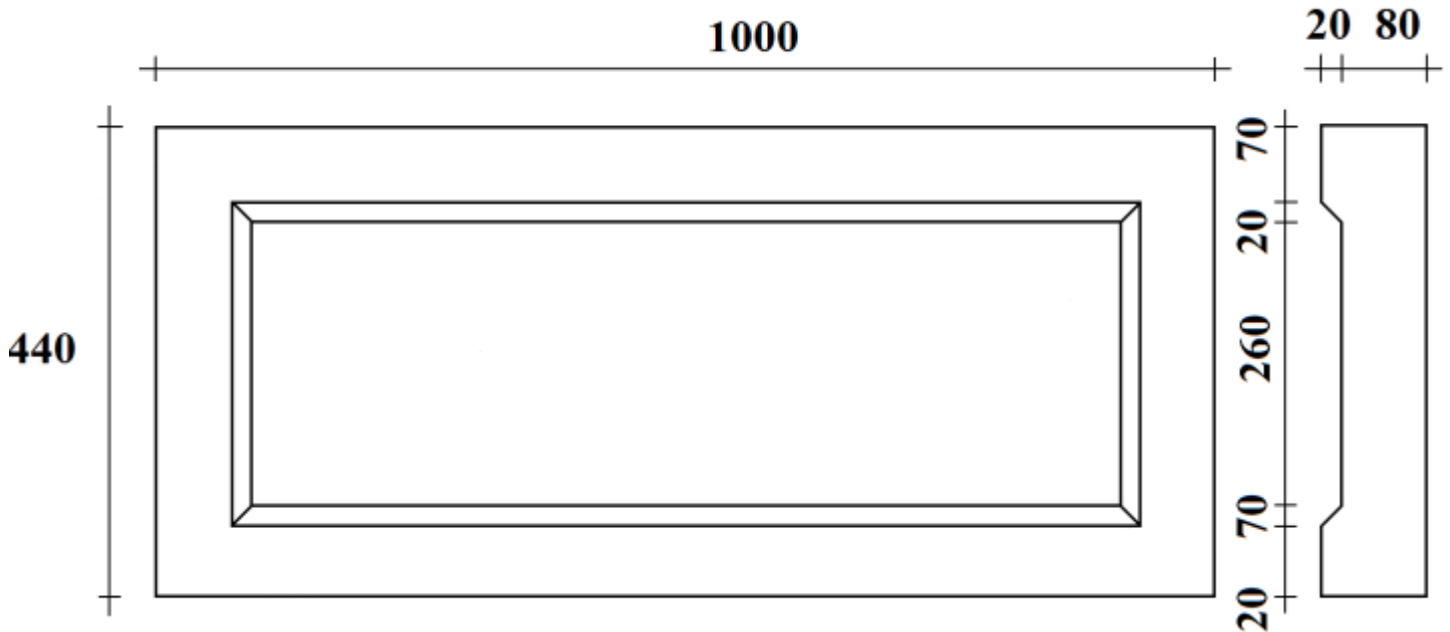

NS1 Recessed Name stone block (carving / painting of lettering at additional cost subject to requirements)

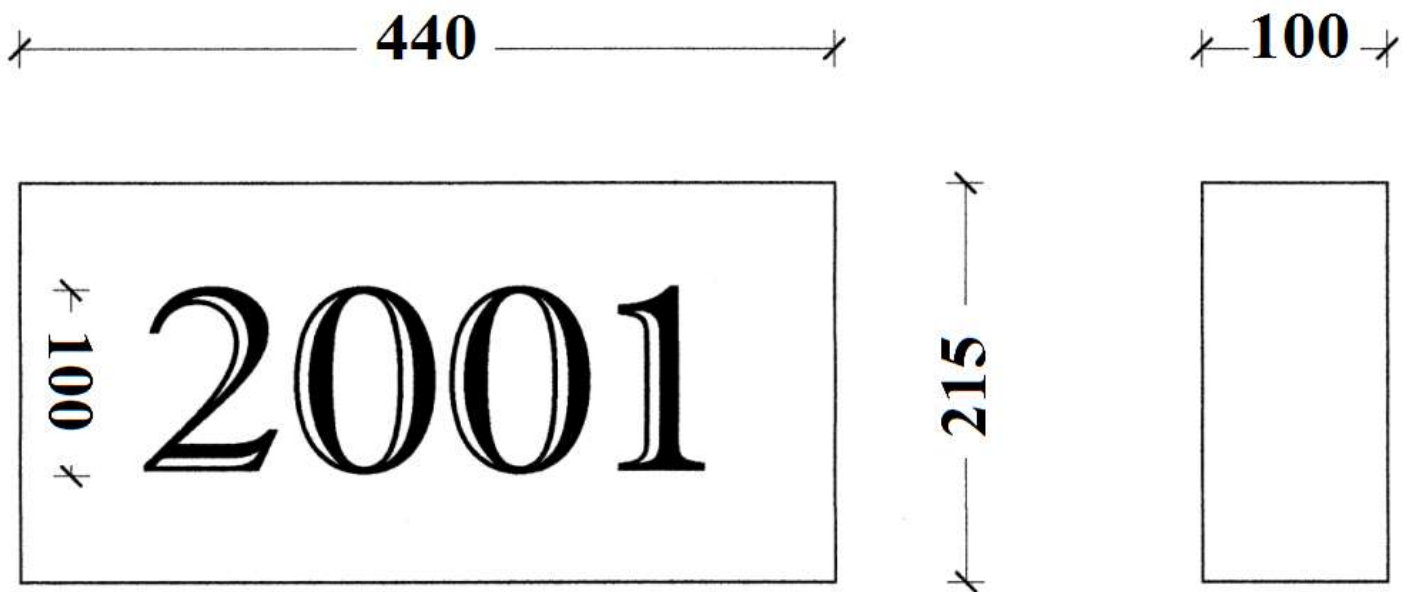

DS1 Plain block with 4no, carved numerals 100mm high (painting of numerals at additional cost)

DS2 Recessed block with 4no, carved numerals 100mm high (painting of numerals at additional cost)

TRADITIONAL WINDOW SURROUNDS 'N' and 'ZN' Ranges

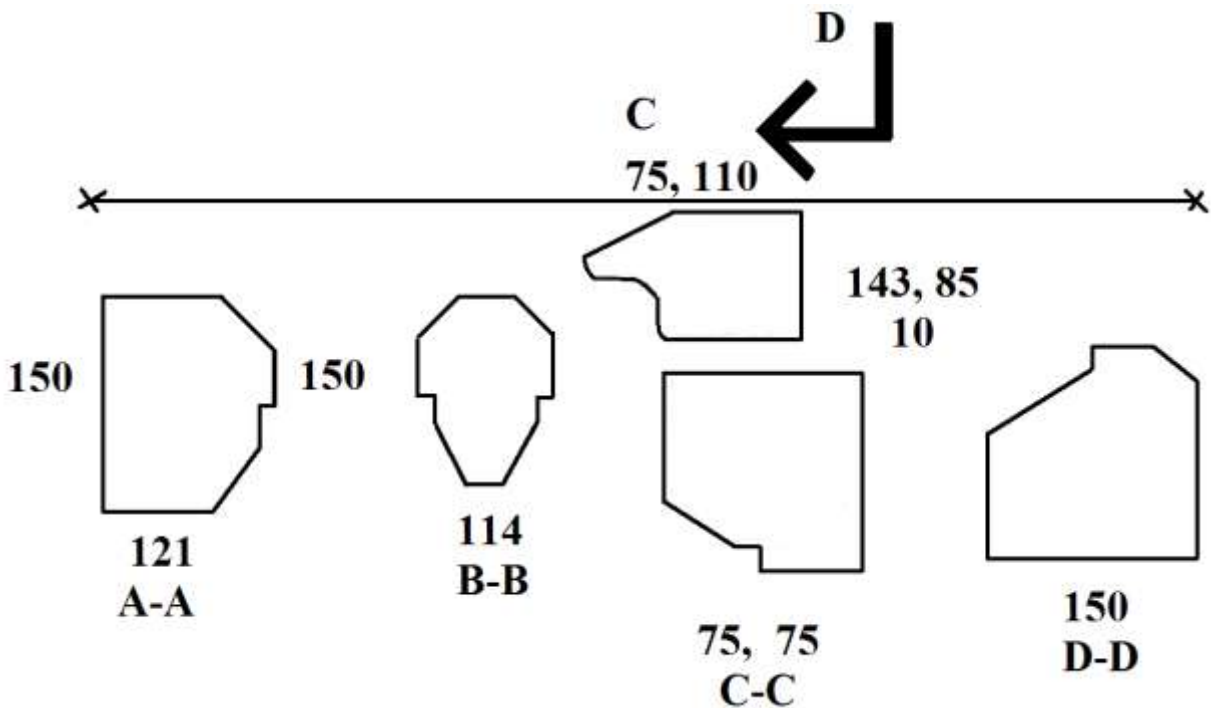
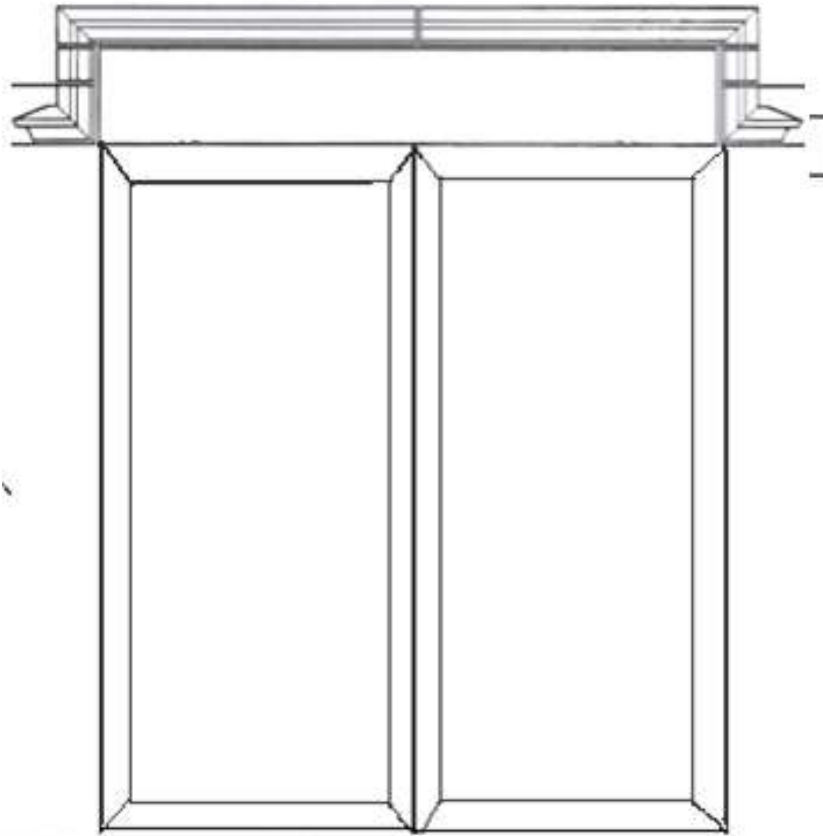

TRADITIONAL WINDOW SURROUNDS

When specifying surrounds, give number of lights & surround types. If bonded jambs are required add suffix 'B.'

If label moulding is required add suffix 'L'.

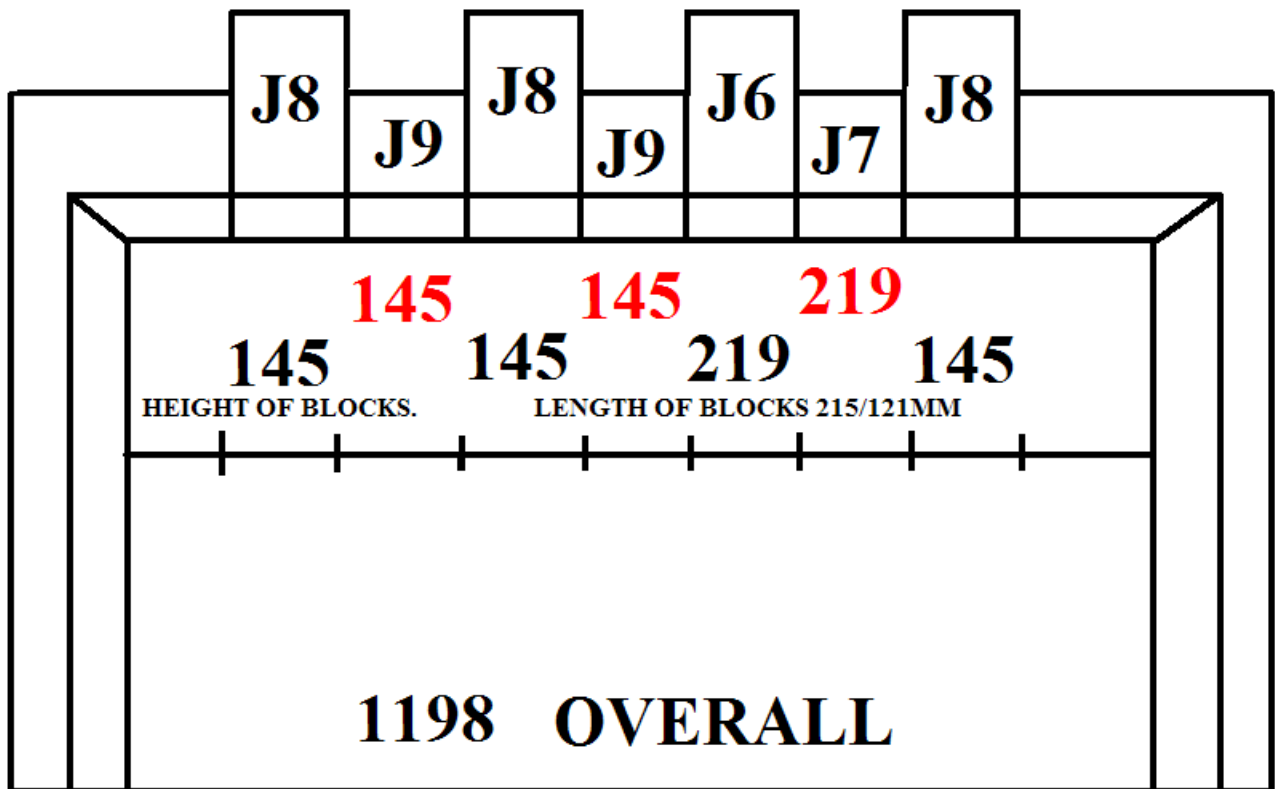

Standard Bonded Jamb Details

CIRCULAR WINDOW SURROUNDS

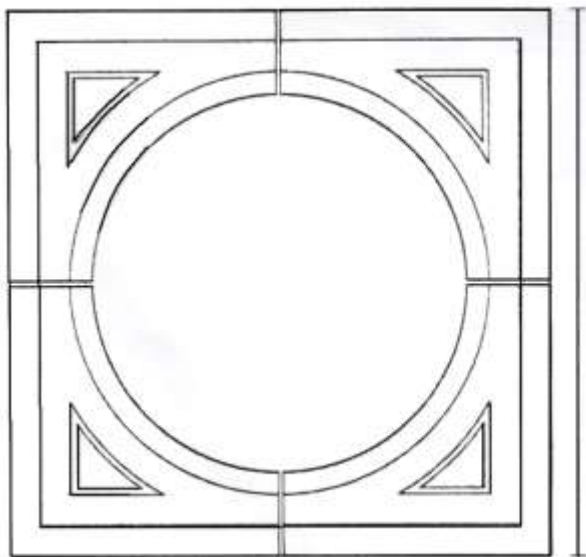
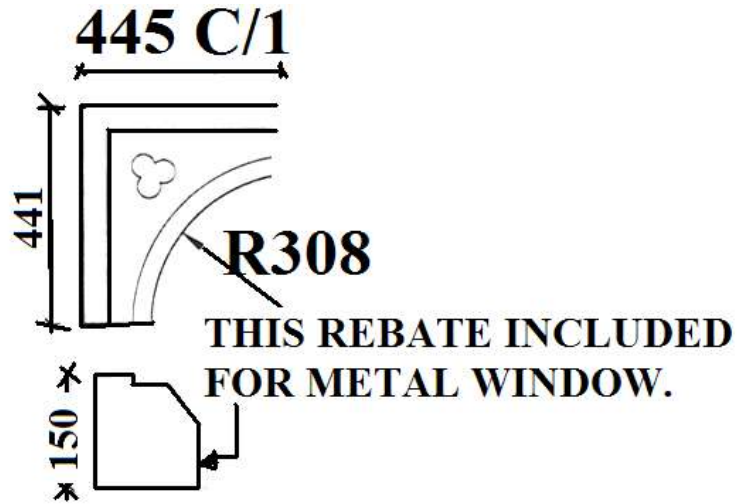
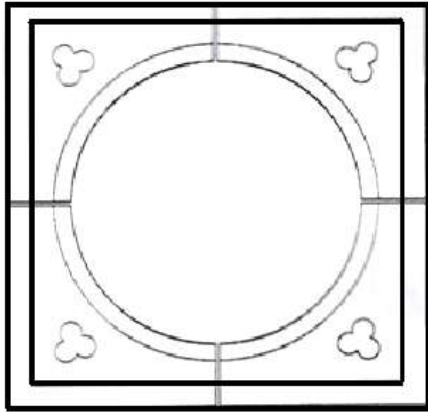

890

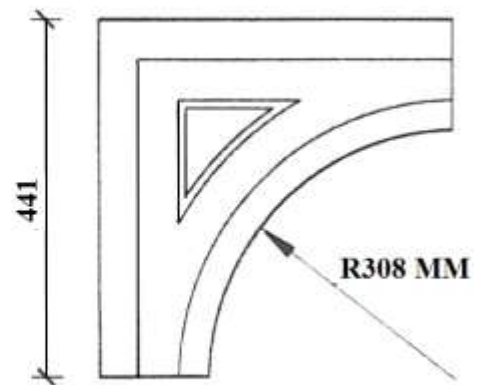

LARGE OVAL WINDOW.

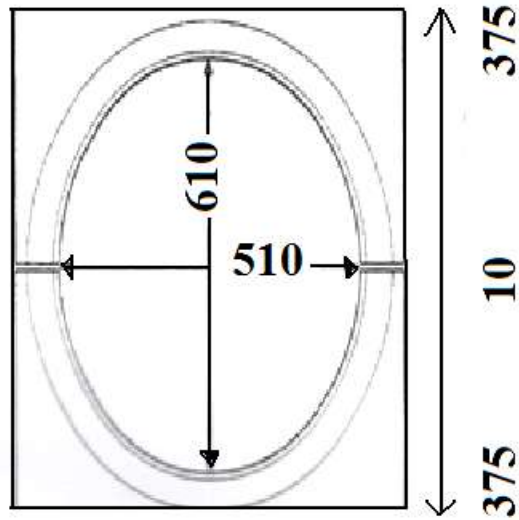

OVAL WINDOW SURROUNDS.

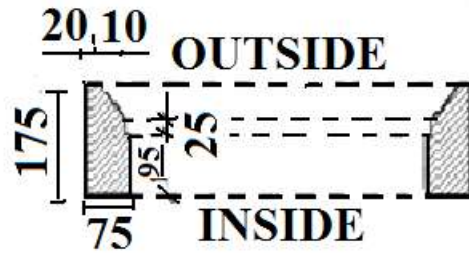

TYPICAL SECTION.

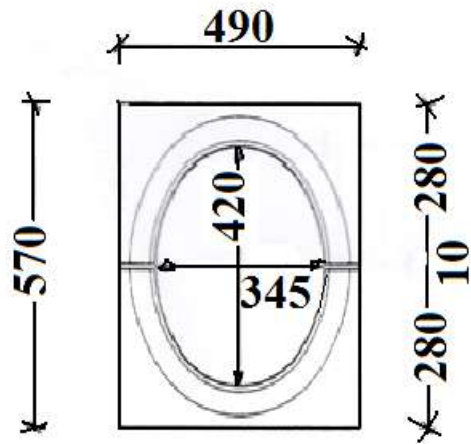

SMALL OVAL WINDOW.

BULLSEYE WINDOW SURROUNDS.

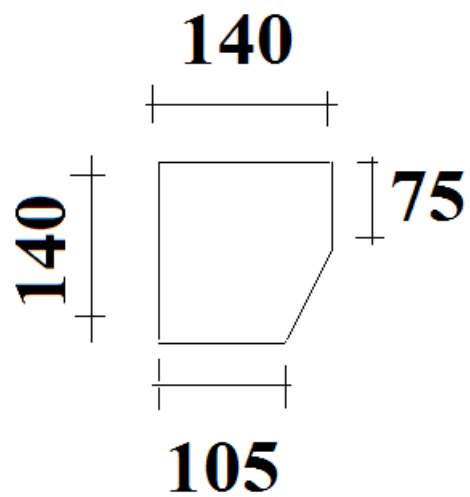
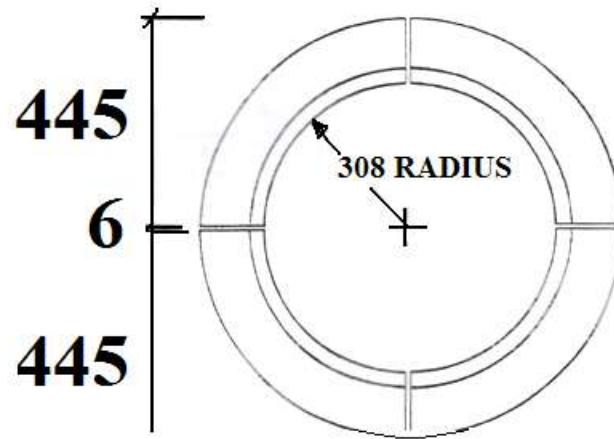

BULLSEYE WINDOW SURROUNDS.

SECTIONAL CIRCULAR WINDOW SURROUND.

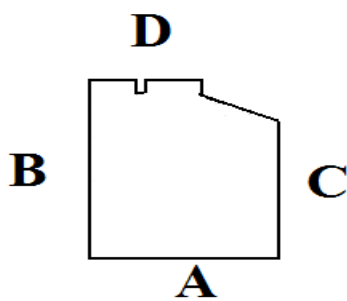
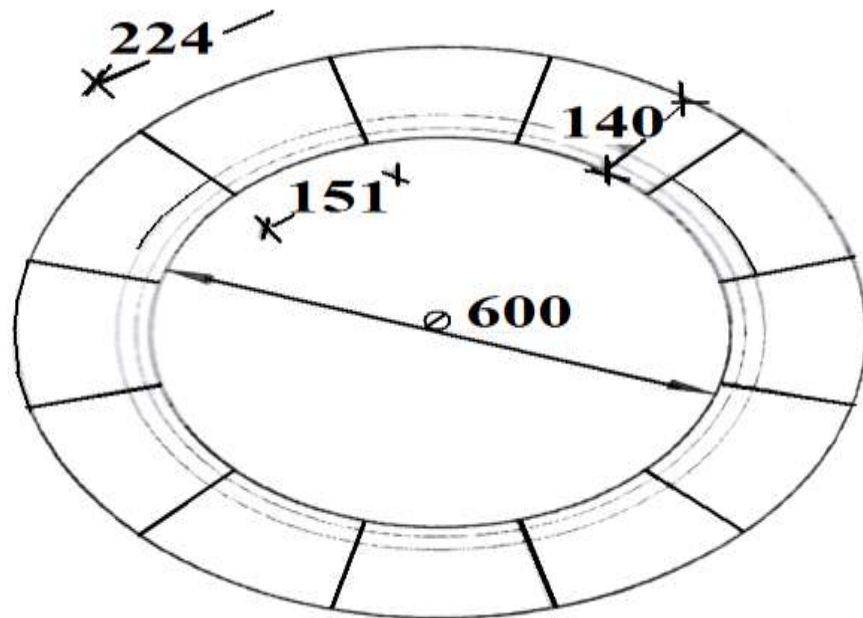

BT1
600MM TIMBER
OR P.V.C-U
FRAMES.

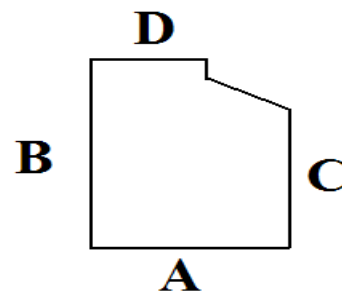

BM1
590MM METAL
FRAMES

TYPE NO.	A	B	C	D
BT1	140	140	105	75
BM1	140	140	105	75

SECTIONAL CIRCULAR WINDOW SURROUND WITH KEYSTONES.

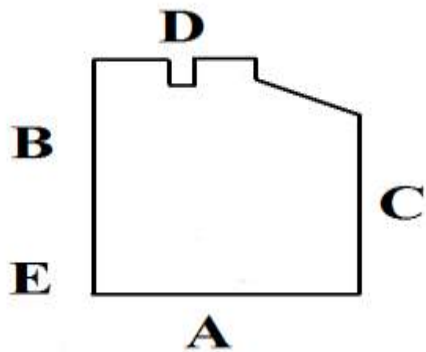
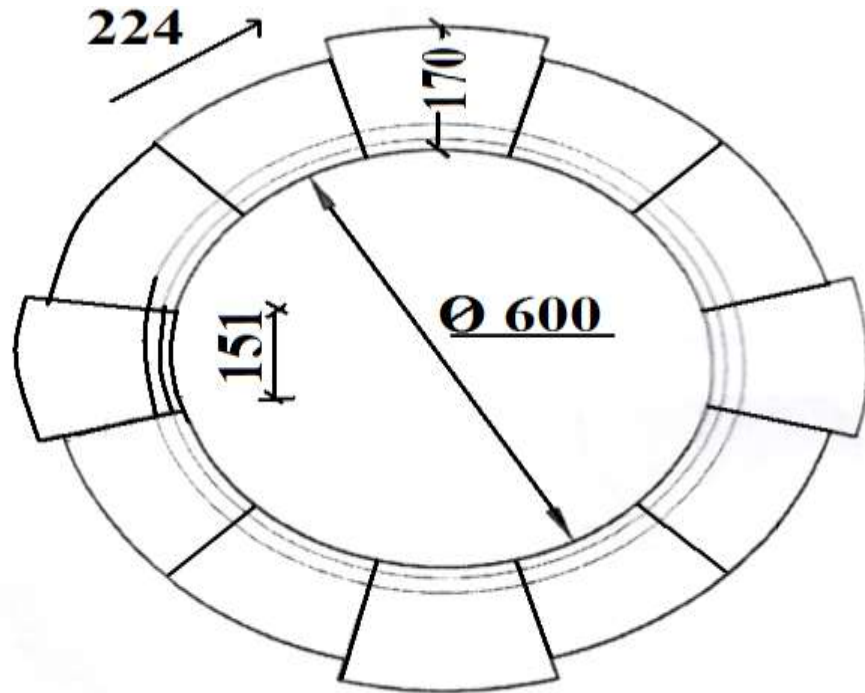

A
BT11

**600MM TIMBER OR
PVC-u FRAMES.**

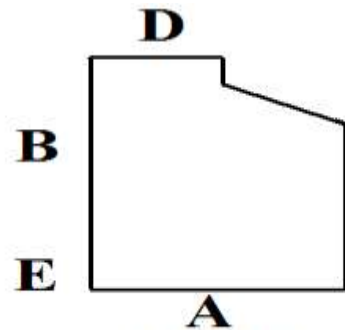

A
BM11
**590MM METAL
FRAMES.**

TYPE NO.	A	B	C	D	E
BT11	140	140	105	75	30
BM11	140	140	105	75	30

DOOR SURROUND

With Straight Jambs and Arched Head

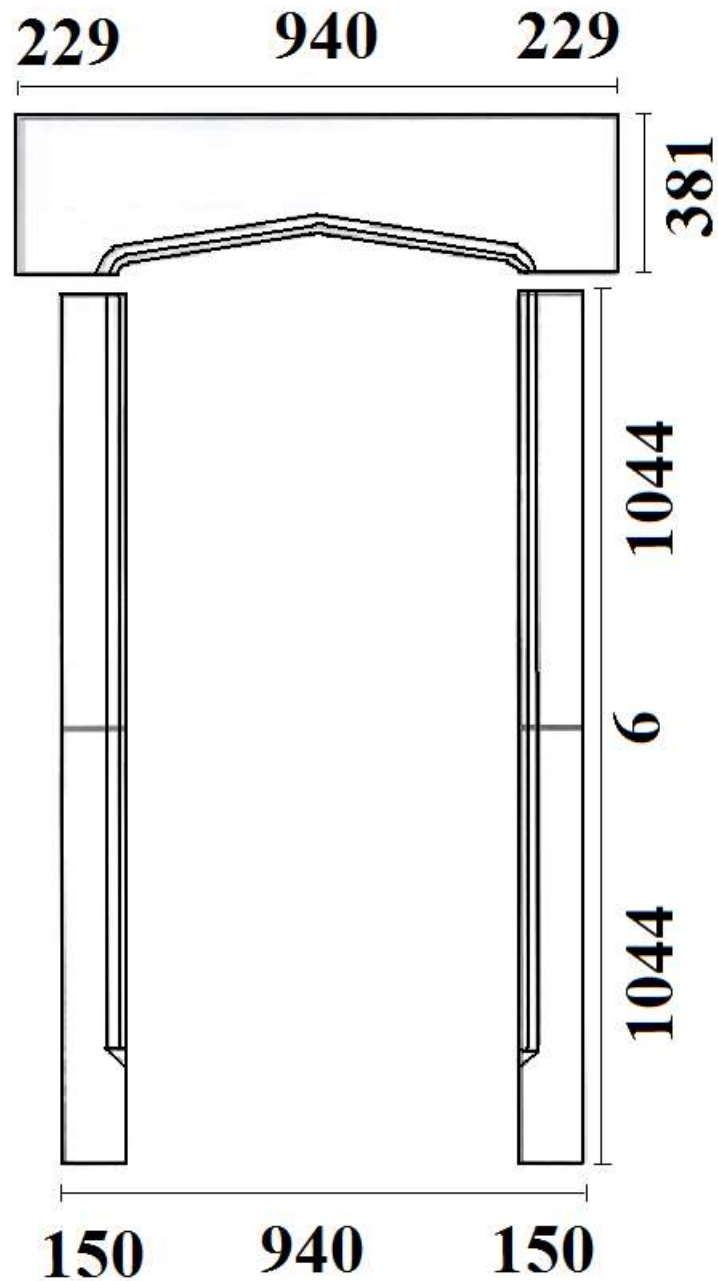

DOOR SURROUND

With Bonded Jambs and Straight Head with
Label Moulding.

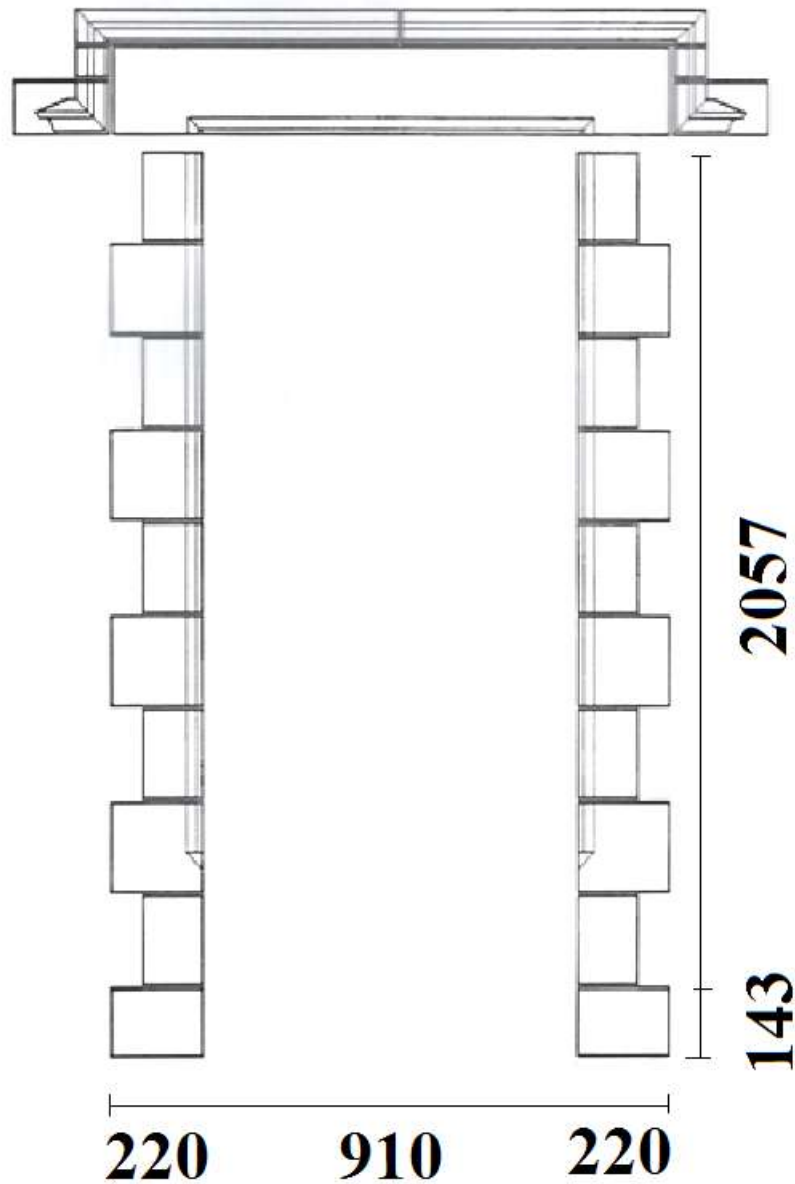

BALL FINIALS

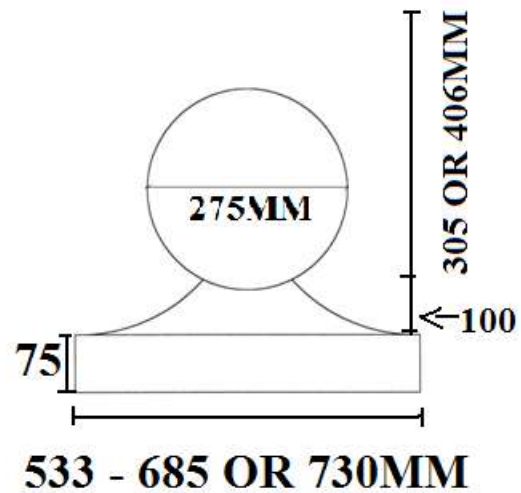
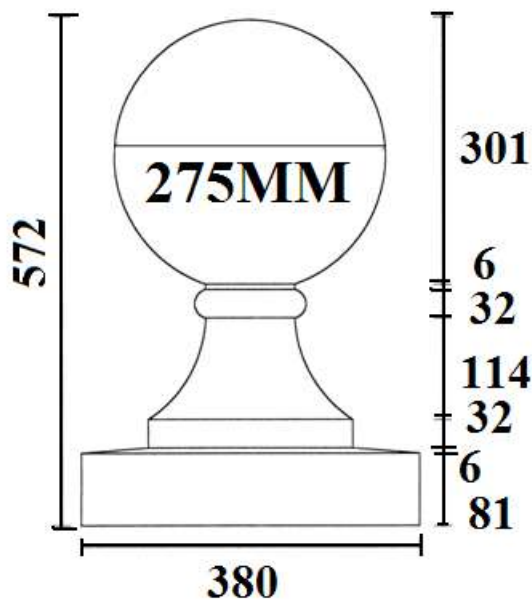
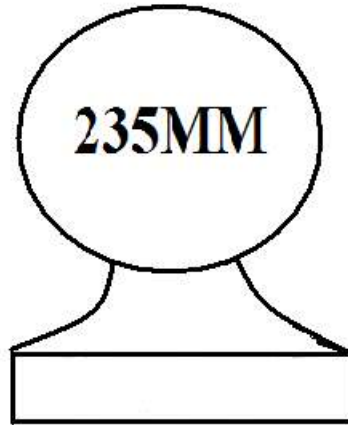

High –necked Ball Finial
(in one-piece)

Swept Ball Finial
(in two pieces)
(fixed with s/s dowel)

Ball may be supplied without base, if required.
Additional flat slab may be added underneath
base to suit larger piers.

BALUSTRADING

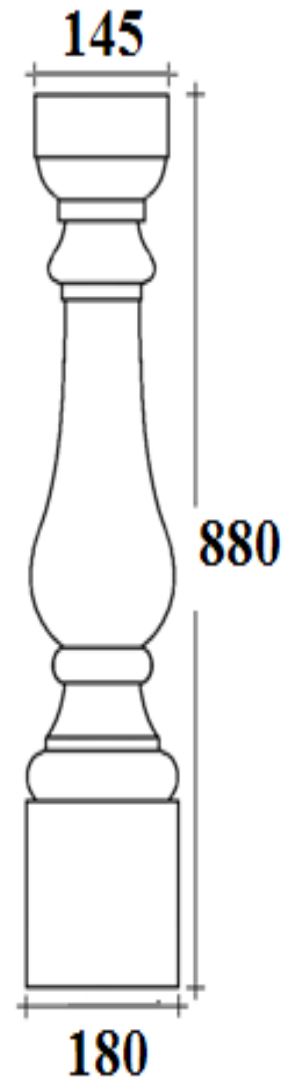
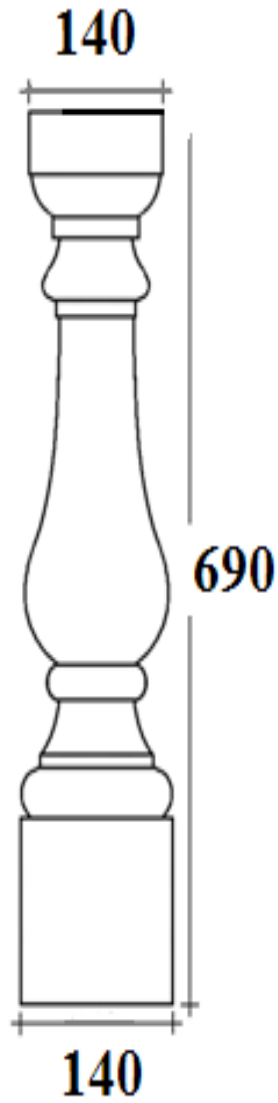
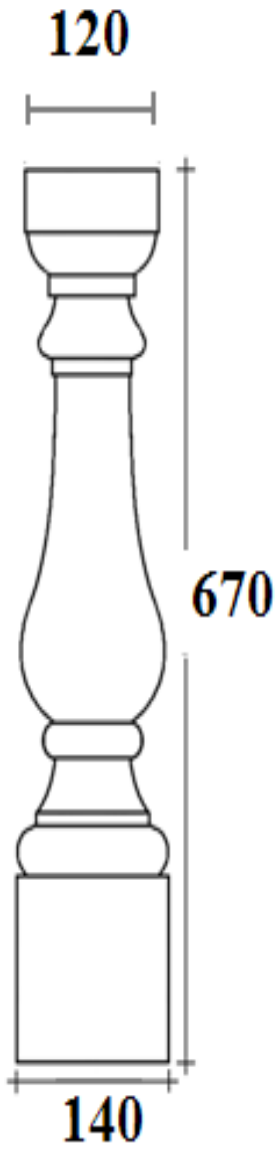

BALUSTRADING

Caps and plinths to suit pier widths also available

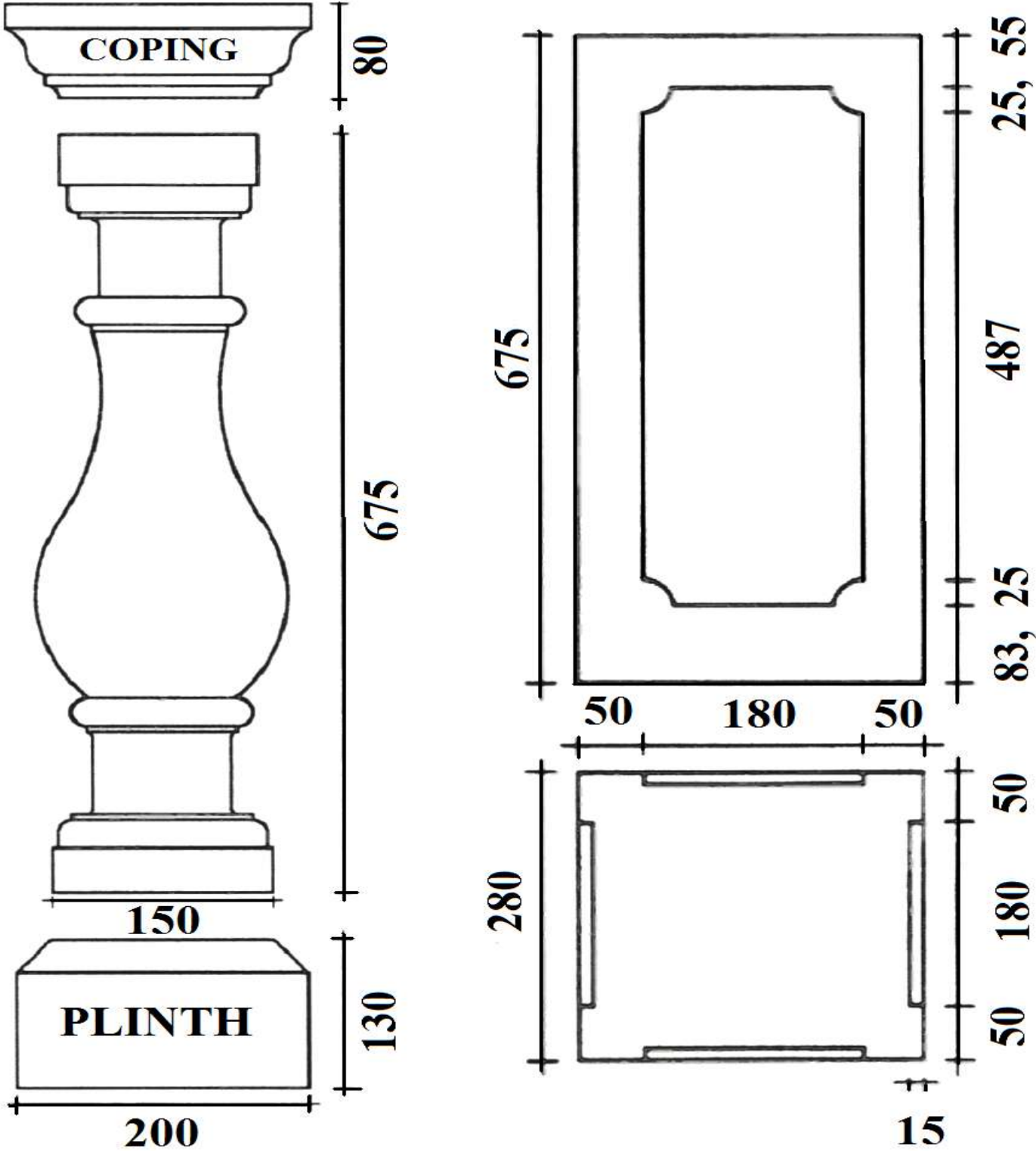

Hollow Section, Tuscan Column

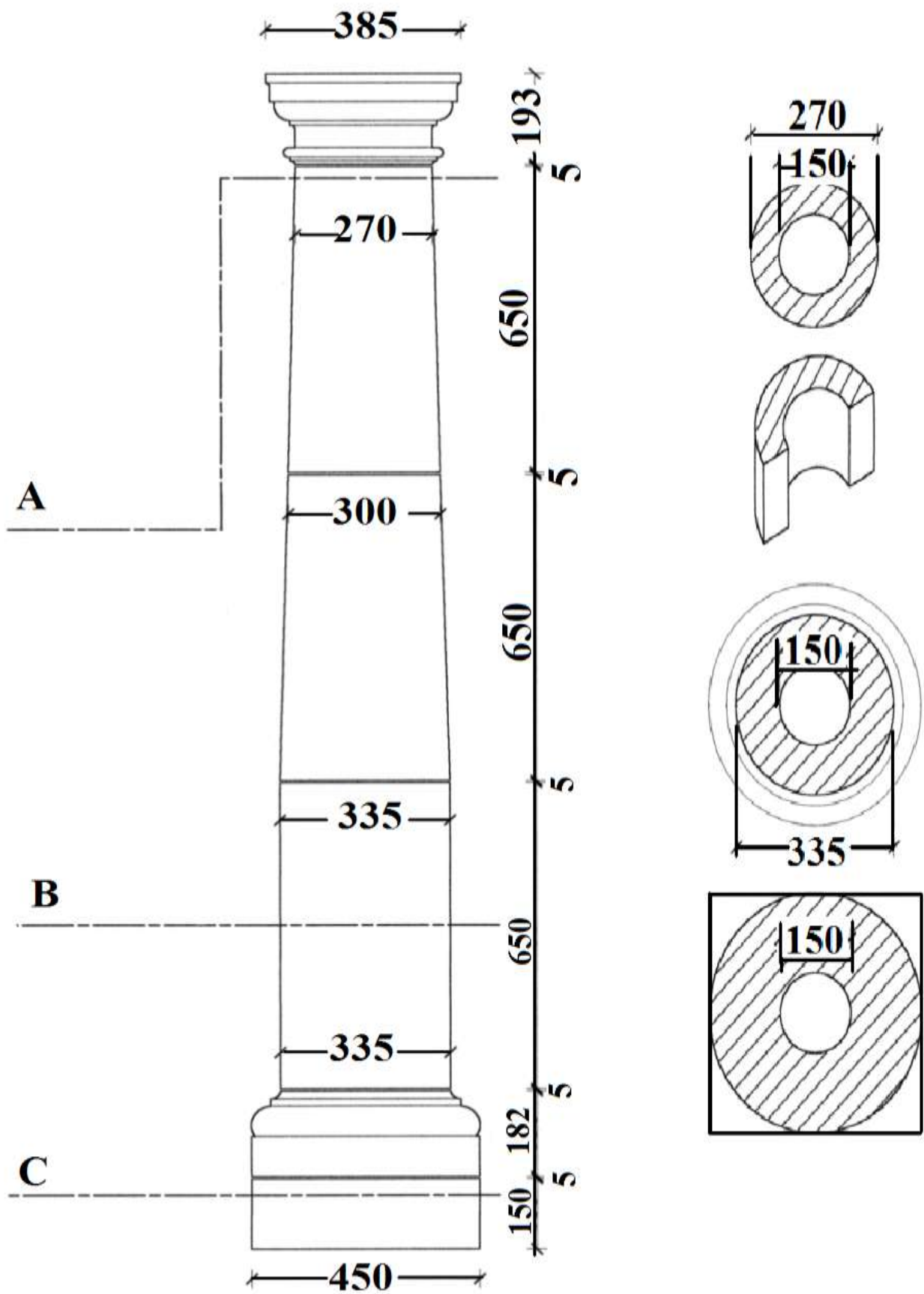

Column.

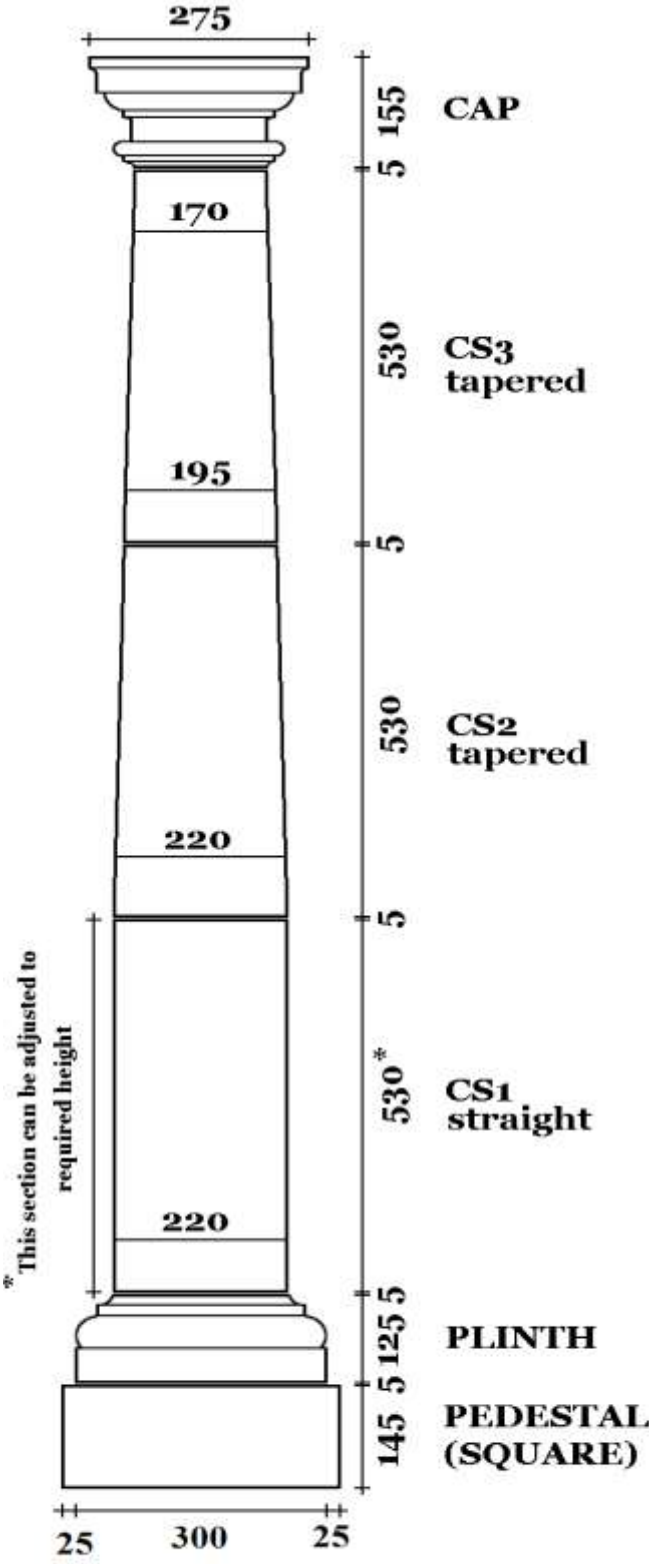

FIREPLACES.

CLASSIC RANGE

Code	Description	Shelf Width mm	Hearth Width mm	O/ALL Height mm
FP/Glos	Gloucester	1450	1765	865
FP/Chelt	Cheltenham	1200	1210	825
FP/Chelt2	Cheltenham (Straight)	1200	1210	825
FP/Lud	Ludlow	1330	1260	923
FP/Caer164	Caernarvon 164	1640	1610	918
FP/Caer 194	Caernarvon 194	1940	1915	918
FP/Tewk	Tewkesbury	1520	1610	1070
FP/Sud	Sudeley	1350	1440	1070
FP/Sud2	Special Sudeley 1084	1084	1150	1070
FP/Pains	Painswick	1340	1260	938
FP/Den	Denbeigh	1355	1500	1155
FP/Chal	Chalford	1220	1220	1045

FIREPLACES.

All fireplaces are available in any of our standard colours – samples available on request.

The 3 – piece central inset is available in different sizes to suit the opening required.

Fireplaces can be manufactured without recesses for insets if advised at time of ordering.

Hearths and other components are available separately, if required.



HAMPTON CAST STONE LIMITED

1. These terms & conditions apply to all sales by Hampton Cast Stone (the Company'). No variation to these conditions will apply without written approval of a Director of the Company.
2. All rates are ex-works unless otherwise stated. Delivered rates are costed for a fully-loaded articulated vehicle, with part-loads being surcharged at rates ruling at the time of delivery. The Company does not undertake to deliver or collect any load over roads or other ground which it considers to be unsuitable. If a vehicle used for performing a contract with any Customer is required to visit a site situated off a hard roadway, the Customer is to be solely responsible for any accident or damage resulting in consequence. Failure to comply may result in the Company refusing to make delivery or collection, and charging the Customer with the costs incurred.
3. All rates quoted are based on fluctuating costs. Goods will be invoiced at the rates ruling on the date of collection or delivery, and any variation in price shall be binding on the Customer. The Company reserves the right to charge for any additional costs resulting from any variations to the contract, or changes to the specification of goods made at the request of the Customer. In particular, where goods are made specially to order, an order for these products, once received, will be put in hand, and any additional costs incurred by the Company as a result of subsequent changes or cancellation shall be passed onto the Customer.
4. The Customer may not cancel the contract or part of the contract without the consent of the Company. If such consent is given, it is made on the express condition that the Customer shall indemnify the Company against all loss, damage, claims or actions arising out of such cancellation, unless otherwise agreed in writing.
5. Goods sold by the Company shall be of the type, description and/or specification as shown on our delivery note or the quotation, and shall accord with the specification stated or as relevant by usage of the industry for the type stated. No higher specification is to be implied.
6. All quotations for goods ex-stock are subject to being unsold on receipt of order.
7. If goods are offered and supplied to the Customer's design and specification, no warranty or guarantee is given or implied of their suitability for the purpose for which they are used.
8. Unless expressly stated, the Company's offer does not include drawing services. Fully-dimensioned drawings will be required from the Customer before manufacture can commence. Where drawing services are offered at additional cost, the Customer must approve all details in writing prior to manufacture.
9. Unless expressly stated in the Company's offer, the contract is not a Sale by Sample.
10. The Contract between this Company and the Customer shall incorporate our Quotation Assumption Sheet, and shall come into effect only when the Customer's order is accepted by the Company in writing. Variations, amendments or additions to the Customer's requirements will only be acted upon by the Company on the proper receipt of written confirmatory instructions from the Customer.
11. If credit facilities are not already in existence for the Customer, the Company may require payment of a 25% deposit at the time of order, followed by cleared payment of the balance prior to delivery or collection of the goods. Credit facilities may be offered at the discretion of the Directors of the Company.
12. Payment for goods supplied on credit must be received by the Company no later than the last working day of the month following the month of invoice, and no discount shall be allowed in respect of any late payments. If (a) as a result of making a delivery the Customer's credit limit would be exceeded or (b) the Customer fails to comply with payment terms or any other of these Conditions, then the Company may refuse (whether under this or any other contract between the Company and the Customer) to accept or complete any order, suspend supplies or impose such special payment terms or other conditions as it deems appropriate. In the case of late payment, the Customer shall pay the Company interest on the net payment due at the rate of 8% per annum above bank base rate, calculated from the date payment was first due until the date when payment has been received by the Company.
13. The Company reserves the right to require full and cleared payment for the goods prior to delivery or despatch.
14. Payment on or before the due date is of the essence of the Contract and is a condition precedent for any future deliveries to the Customer or to its order. The Customer will be charged for all storage charges and other costs incurred as a result of non-payment or delayed delivery.
15. All payments due from the Customer under these Conditions shall be made without any set-off, deduction or deferment of any nature.
16. Where the Company has agreed that the goods may be paid for by instalments, any failure by the Customer to pay an instalment when due shall entitle the Company to treat such failure as the Customer's repudiation of the whole contract without prejudice to its other rights to recover damages for that breach.
17. The Customer should examine the delivered materials and satisfy himself that they are in good order before signing delivery notes. Any damage found should be notified to the Company immediately, and confirmed in writing within 7 days. In no circumstances will the Company be responsible for breakages or damage occurring after delivery.
18. Goods are to be unloaded by the Customer immediately on arrival. Waiting time will be charged for every hour or part thereof in excess of the permitted 2 hours off-loading time.
19. Goods will be delivered on pallets, which are non returnable unless agreed otherwise.
20. Time of delivery is not guaranteed without special undertaking. Any programme given for delivery or collection of goods is given or agreed by the Company in good faith, and every endeavour will be made to comply therewith. The Company shall not, however, be liable for any loss or damage consequential or otherwise arising through its failure to make delivery by the due date or time.
21. Property in Goods shall not pass to the Customer until he has paid to the Company all sums owed by the Customer to the Company. Any transaction in goods carried out by the Customer prior to the receipt by the Company of the full sale price shall be in the capacity of Agent for the Company, to whom the Customer shall be fully accountable for any monies received.
22. A restocking charge will be applied to any standard Hampton Cast Stone product returned for credit, unless agreed by the Company to be defective.
23. Goods shall be at the Customer's risk between delivery and payment.
24. All quotations are subject to the Company having the right to refuse to supply goods if it is not satisfied as to the credit-worthiness of the Customer.
25. The Company's liability on goods found and agreed to be defective is confined to free replacement only. The Company shall have no liability whatsoever for any losses or damages which may be sustained by the Customer because of non-delivery in due time or at all, part-delivery, mis-delivery or delivery of defective goods, howsoever caused.
26. The Company does not accept liability for late receipt of information, delays or costs arising from any cause beyond its control, including, but not confined to strikes, lock-outs, accidents, machinery breakdowns and exceptionally inclement weather.
27. If any dispute or difference shall arise between the parties concerning this Contract, such dispute or difference shall be and is hereby referred to the arbitration of a person to be agreed between the parties or, failing agreement, a person appointed at the request of either party by the President for the time being of the Chartered Institute of Arbitrators.
28. The Customer shall not assign or transfer any Contract to which these Conditions apply, nor the benefit thereof to any person whomsoever.
29. The Customer is advised to ensure that the initial order for the Company's products is sufficient to avoid the need for re-ordering, as the Company cannot guarantee that colour and texture will be identical if made at different times. This will also avoid problems on delivery, as re-orders will be taken in rotation with existing orders, and delay may result. Moreover, while the Company will try to maintain the same price for re-ordered quantities, this cannot be guaranteed. All prices quoted are based on the Company's understanding of the quantities required, and a later re-order for a small additional quantity of materials may result in a significantly higher price having to be quoted.
30. While every effort is made to match hand-made special units with goods which are machine-produced, the colour and texture of hand-made special units may vary slightly from the colour and texture of goods produced by machine, and the Company will not accept any liability in respect of such variations.
31. Samples submitted may vary in shade from the goods delivered, due to variances in the natural constituents. The Company will not accept liability in respect of any such variation.

ADDITIONAL STANDARD PRECAST UNITS

Staddlestone



Cloverleaf Birdbath



Stone Bench



Sundial Bases

Didn't find exactly what you were looking for?
Give us a ring or call in to see our Estimator
for a quotation
for manufacturing items
to your own design or size.





St Davids Claitor centre, Hampshire

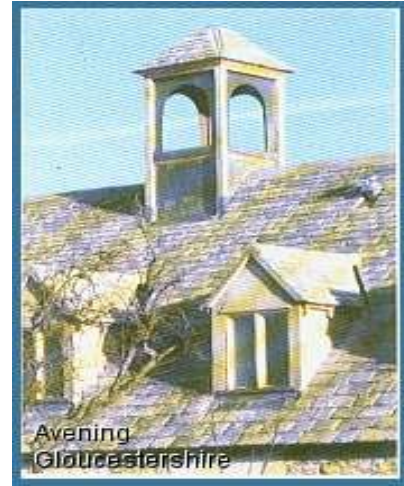

Avening
Gloucestershire



Hampton Cast Stone Ltd

Tel. 01453 836677



Didn't find exactly what you were looking for?







ABERBARGOED 2009







***BESPOKE HANDMADE PRE-CAST STONE
MAKE YOUR HOME A CASTLE.***